

# TOTO

## Two-piece Toilet

CW802EBT305/400#XW

SW802EBT305/400#W



WATER SAVING



CEFIONTECH



RIMLESS



TORNADO FLUSH

### FEATURES

- 3.0L/4.5L flushing system, low consumption.
- Premist technique applied, prevents dirt attached.

### SPECIFICS

Size:

CW802EBT: 695x374x410mm

SW802EBT: 321x168x396mm

Water Inlet Requirement:

0.05MPa(Dynamic Pressure)~

0.75MPa(Static Pressure)

Dual Flush Volume:4.5/3.0L

Nominal water consumption :

3.5L

Water Efficiency: Grade1

Flush type: Tornado Flush

Drainage mode:

Underneath Drainage

Rough-in :

305mm;400mm

### CW802EBT305/SW802EBT305 CW802EBT400/SW802EBT400 Two-piece Toilet

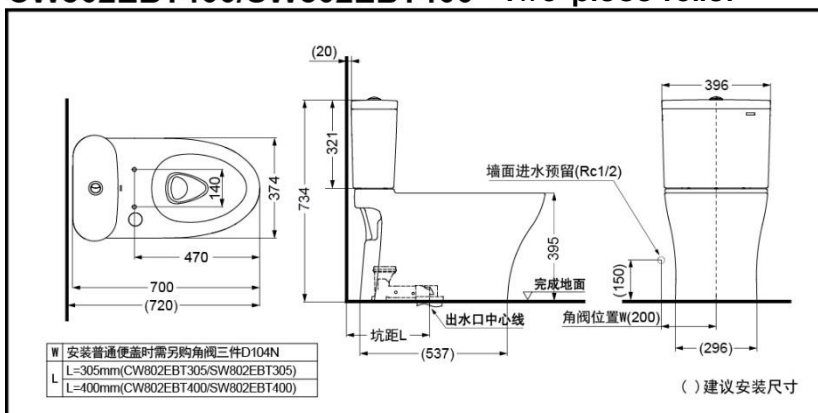

### OTHERS

Recommend fittings :

Washlet: C2,S2series

TC400CVK-1; TC401CVK-1

Toilet installation kit:

D106A; D104N.