

4

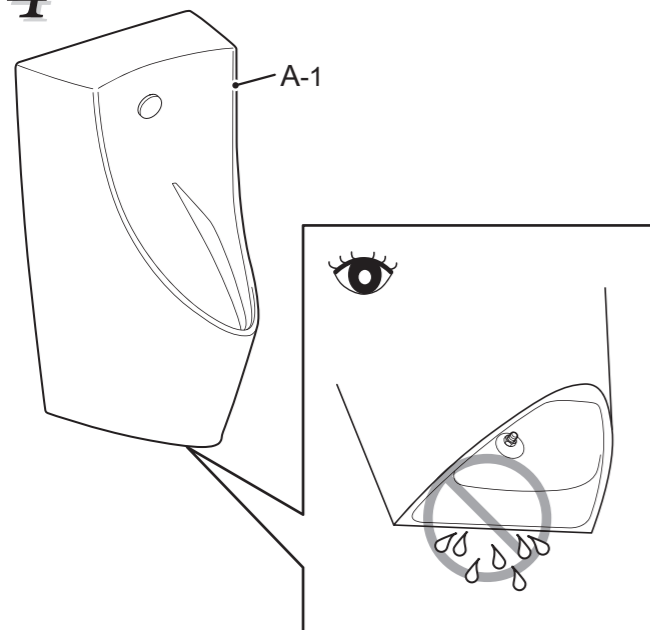

5

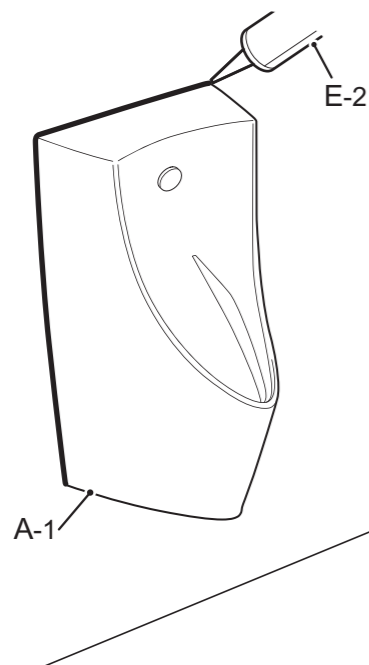

6

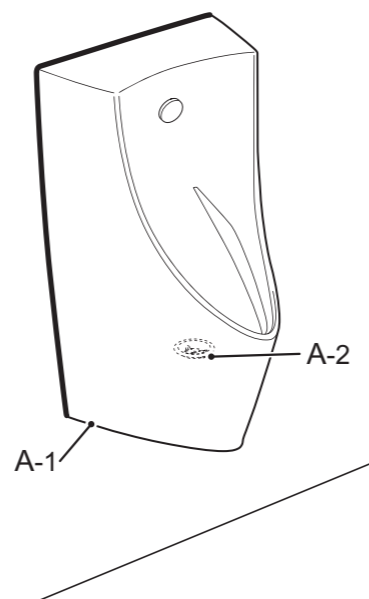

TOTO

施工说明书 / Installation Guide /
施工說明書

壁挂式节水型小便器 Wall Mounted Urinal 壁掛式小便斗

UWN903系列
UFWN903系列
U901系列
UWN901系列 /
UFWN901系列 /
UWN903 SERIES
UFWN903 SERIES
U901 SERIES
UWN901 SERIES
UFWN901 SERIES /
UWN903系列
UFWN903系列
U901系列
UWN901系列
UFWN901系列

安全注意事项/安装前的注意事项 Cautions and Warnings/Before Installing 安全注意事項/安裝前注意事項	• • •	P.2 P.3 P.4
完成图/As-fitted Drawing/ 完成圖	• • •	P.5
同捆零件/Included Parts / 包裝內零件	• • •	P.6
需准备的工具/Required Tools/ 需準備的工具	• • •	P.6
关于各部位/About Parts/ 關於各部位之說明	• • •	P.7
安装方法/Installation Method/ 安裝方法	• • •	P.7

ZH 注意

!
必须实行
禁止使用环氧树脂或者硬化后体积变大的密封材料。否则，由此导致的产品损失，我司概不负责。

EN CAUTION

!
Required
Sealing materials such as epoxy resin that have a tendency to increase in volume after curing shall not be used.
Our company shall not bear any responsibility with respect to any damages in the Sanitaryware caused by the use of such a kind of sealing materials.

TW 注意

!
務必執行
絕對禁止使用環氧樹脂膠等硬化後體積會變大的密封材料，由此所引起的陶瓷開裂等情形，本公司一概不負責任。



为了充分发挥产品的性能，请按施工说明书内容正确安装。
安装后，请向顾客详细说明使用方法。 /

Perform the installation work properly according to this Installation Guide so that the product can function well.
After installation, fully explain how to use it to your customer. /



為充分發揮商品機能，請依照本施工說明書內容正確安裝。
安裝後，請向顧客詳細說明使用方法。



安全注意事项 (为了您的安全, 请务必遵守)



安装前, 请仔细阅读「安全注意事项」。并根据其内容正确安装。
为了使您能正确地安装该产品, 防止危害您或他人的安全及财产损失, 本说明书记载了各种标志。
标志的意思说明如下。

 警告	表示如果忽视该标志栏的内容, 错误操作, 将可能导致人员死亡或重伤。	 注意	表示如果忽视该标识栏的内容, 错误操作, 将可能导致人员受伤或财产损失的内容。
---	------------------------------------	---	---

应遵守的内容种类用以下标志区分进行说明。

	表示不可以做的“禁止”内容 左图表示的是“禁止”		表示必须实行的“强制”内容。 左图表示“必须实行”。
	表示不得进行的“禁止”内容。 左图表示“禁止在浴缸、淋浴间使用”。		

 警告	
 潮湿环境禁止使用	<ul style="list-style-type: none"> 不要安装在浴室内等潮湿场所 否则会造成故障、漏电。
 禁止拆解	<ul style="list-style-type: none"> 除维修技术人员之外, 其他人绝不要拆解、维修、改装 否则有可能会引起故障、触电、受伤。



 注意	
 禁止	<ul style="list-style-type: none"> 请勿撞击陶瓷 陶瓷破裂后会造成人身伤害、漏水及污损家具等后果。
 必须实行	<ul style="list-style-type: none"> 必须按照说明书进行安装。 否则可能会造成故障或漏水。
	<ul style="list-style-type: none"> 必须要有2人以上进行施工 否则有可能会使腰受伤, 或是陶瓷掉落造成损坏。 施工后, 必须要进行试运行, 确认各部分没有漏水 如安装不到位有可能会发生漏水, 导致财产损失, 如淋湿家具等。

安装前的注意事项







- 给水和电器施工前, 请对施工工序进行充分的商讨。
- 由于包装前会进行通水检查, 因此商品内有可能留有水分, 但对商品无影响。
- 请不要在0°C以下环境中使用和储存, 防止冻裂。



Cautions and warnings (For safety, be sure to follow these)



Before installation, read these "Cautions and Warnings" carefully and attach the equipment correctly.
This manual uses various symbol examples to provide guidance on safely installing the product and to prevent injury to customers or other people and damage to property.
The symbol examples and their meanings are as follows.

 WARNING	This indicates that misoperation could result in death or serious injury.	 CAUTION	This indicates that misoperation could result in injury or property damage.
--	---	--	---

The types of information that must be followed are classified and explained with the following pictograms.

	The  symbol indicates something that is prohibited.		 indicates a required step in the use of this product. The symbol to the left indicates the action is "Required."
	 indicates a prohibited use of the product. The symbol to the left indicates that "use is prohibited in bathrooms and shower stalls."		

 WARNING	
 Use prohibited near water	<ul style="list-style-type: none"> Do not install in locations of high humidity such as bathrooms Doing so may cause a malfunction or current leak.
 Do not disassemble	<ul style="list-style-type: none"> People other than repair technicians should never disassemble, repair, or alter the product Doing so may cause a malfunction, electrical shock, or injury.

 CAUTION	
 Prohibited	<ul style="list-style-type: none"> Do not subject the porcelain to strong forces or impacts Doing so may damage the porcelain and cause an injury, or cause flooding that may damage property, such as household belongings.
 Required	<ul style="list-style-type: none"> Carry out the installation work according to this installation manual Otherwise, damage caused by water leaks may occur.
	<ul style="list-style-type: none"> Always carry out construction work with at least two people Otherwise, the installer may injure his or her lower back, or drop the porcelain and damage it. After construction, be sure to give the product a test run and check that there are no water leaks in any part Not installing the product properly may cause water leaks that could result in flooding damage to property, such as household belongings.

Before Installing



- Thoroughly discuss the relevant procedures before performing water work.
- A water supply inspection has been conducted prior to packaging. There may be some water remaining inside the product, but this is normal.
- To prevent frost damage, do not use or store in an environment below 0 ° C.



安全注意事項 (為安全起見請務必遵守)





施工前請詳閱「安全注意事項」，再正確施工。
為使您安全正確地安裝本商品，並防範對您及其他使用者造成危害或財產損失，本說明書中列出各種不同標示。
各標示及其含意如下所示。

 警告	若忽視本標示欄的內容而操作錯誤，可能會導致人員死亡或重傷。	 注意	若忽視本標示欄的內容而操作錯誤，可能會導致人員受傷或財物損失。
--	-------------------------------	--	---------------------------------

以下列圖示區分，說明應遵守內容的種類。

	代表絕對「禁止」的行為。 左圖表示「禁止」。		代表務必執行的「強制」內容。 左圖表示「務必執行」。
	代表絕對「禁止」的行為。 左圖表示「禁止在浴室使用」。		

 警告	
	● 請勿設置於浴室等溼氣較重的場所 否則將導致故障、漏電。
	● 修理技師以外的人員請勿自行拆解、修理與改造 否則可能導致故障、觸電與受傷。

 注意	
	● 請勿對陶器施加重力或撞擊 可能導致陶器破損，造成人員受傷或漏水弄溼設備等的財物損失。
	● 安裝時請遵照本說明書確實執行作業 否則將導致故障與漏水。
	● 請務必2人以上一同進行施工 否則可能導致腰部受傷，或陶器掉落破損。
	● 施工後，請務必進行測試運轉，確認各部位沒有漏水情形。 若安裝不良，可能會發生漏水弄溼設備等的財物損失。

安裝前注意事項

- 水管管路施工，請於事前充分討論後再進行。
- 包裝前因進行通水檢查，商品內可能有殘留水，此非產品發生問題。
- 為避免凍裂，請勿使用・保管於 0℃ 以下的環境。

完成圖/As-fitted Drawing/完成圖

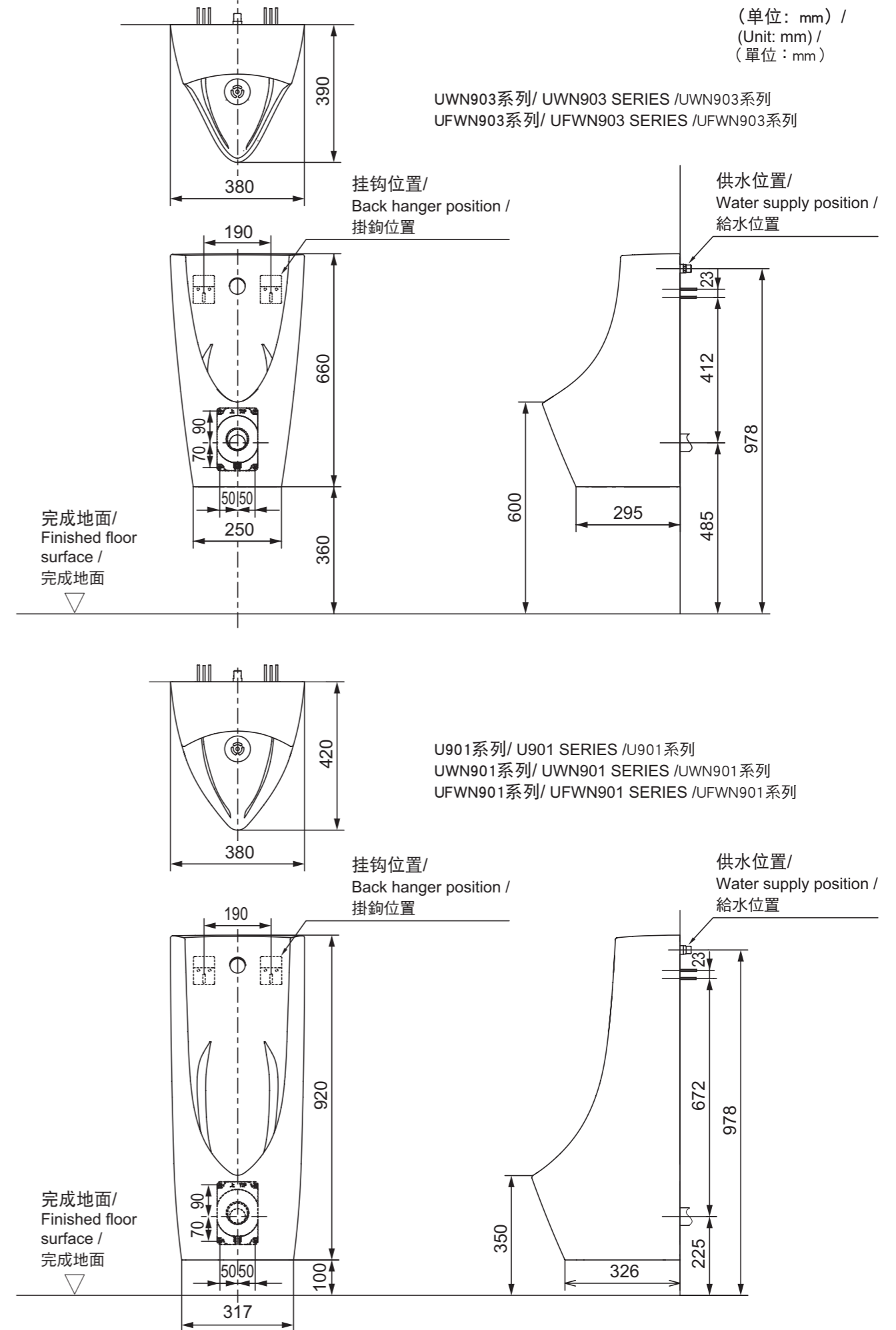

同捆零件/Included Parts/包裝內零件

※由于型号不同，图和实物的形状会略有差异。/

* The product may be slightly different in shape than the product shown in the figure depending on the model. /

※依型號不同，圖示與實際產品的形狀可能有部分差異。

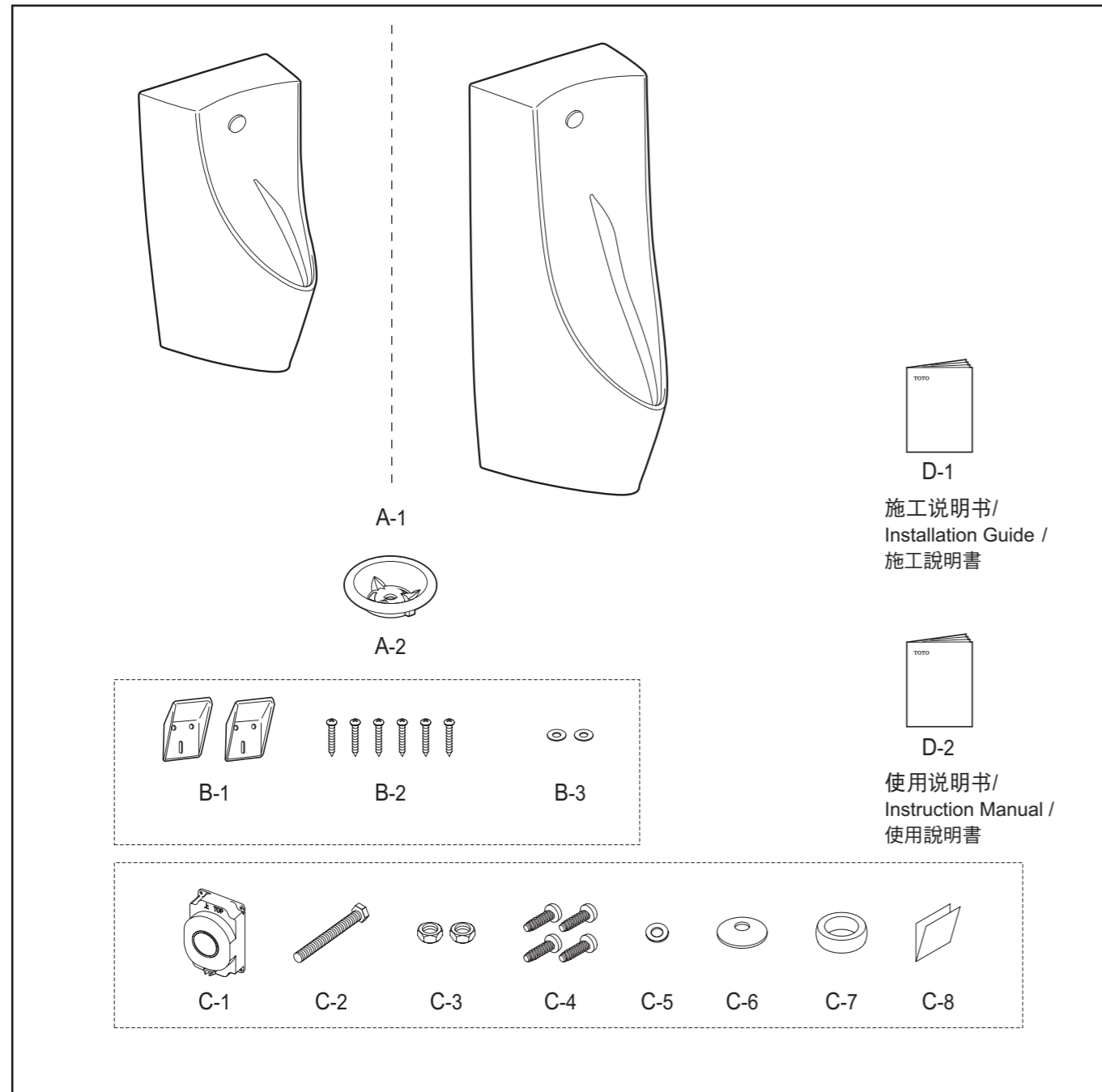

需准备的工具/Required Tools/需準備的工具

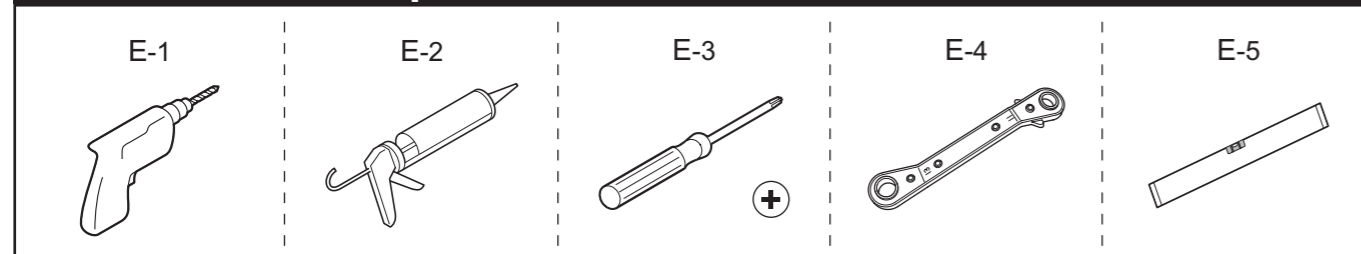

关于各部位/About Parts/關於各部位之說明

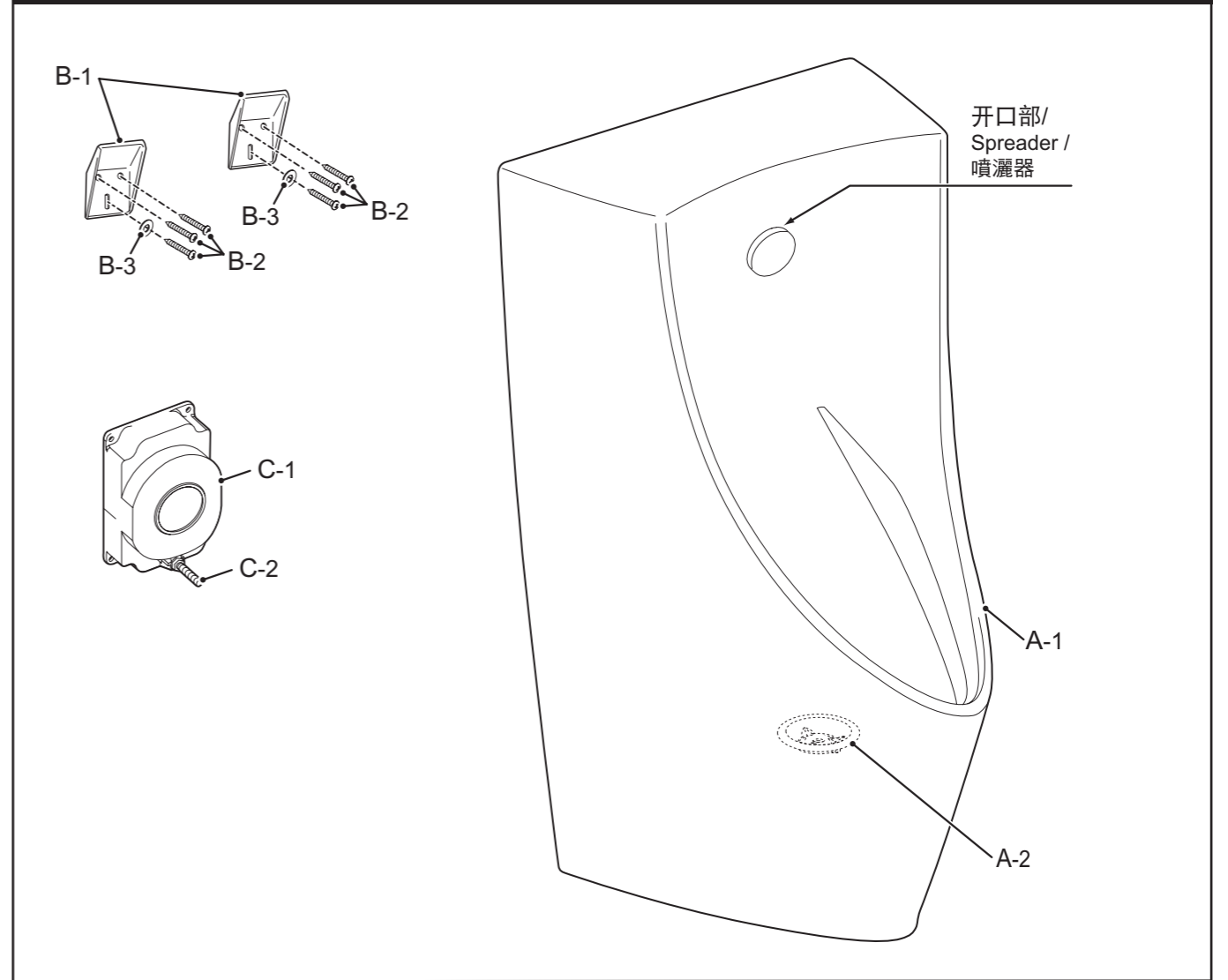

安装方法/Installation Method/安裝方法

ZH 标志的意思

↓ : 安装者必须实施的操作。

👁️ : 必须确认的作业。

⇓ : 操作流程。

EN Meaning of the symbol examples

↓ : Task that must be conducted by the installer.

👁️ : Work that requires confirmation.

⇓ : Shows the work sequence.

TW 關於圖示的意義

↓ : 代表施工者必須執行的作業。

👁️ : 代表必須進行確認的作業。

⇓ : 代表作業的流程。

1

请按附件施工说明书安装排水法兰。/ Install the drainage flange according to the enclosed Installation Guide. / 排水法蘭的安裝方法，請依照排水法蘭包裝內的施工說明書安裝。

后背吊钩 (B-1) 的安装方法 /
Back hanger (B-1) installation method /
掛鉤 (B-1) 安裝方法

1

尺寸 / size / 尺寸

型号 / model / 型號	※1	※2	※3
UWN903系列 / UWN903 SERIES / UWN903系列	95mm	412mm	485mm
UFWN903系列 / UFWN903 SERIES / UFWN903系列			
U901系列 / U901 SERIES / U901系列			
UWN901系列 / UWN901 SERIES / UWN901系列	95mm	672mm	225mm
UFWN901系列 / UFWN901 SERIES / UFWN901系列			

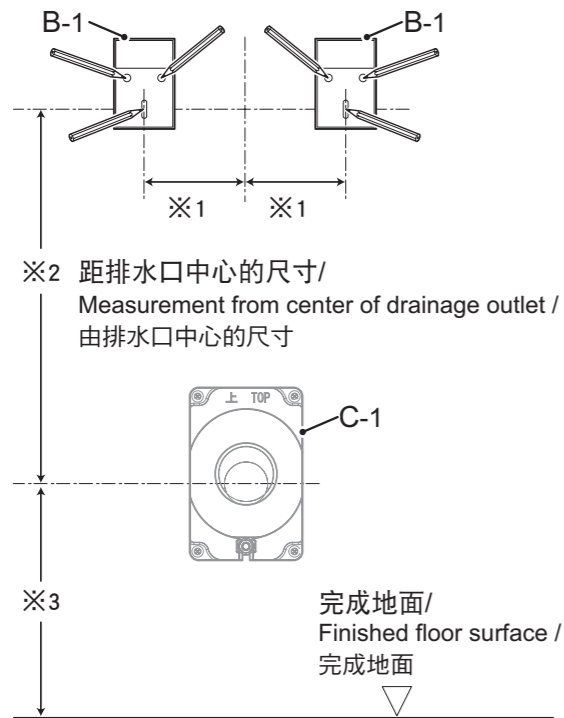

2

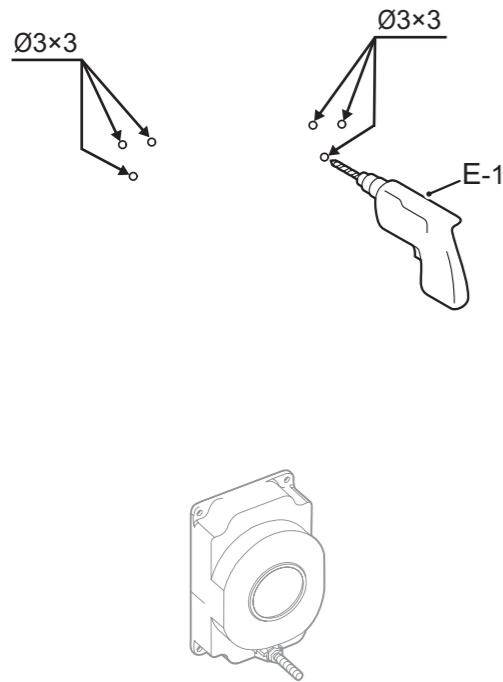

3

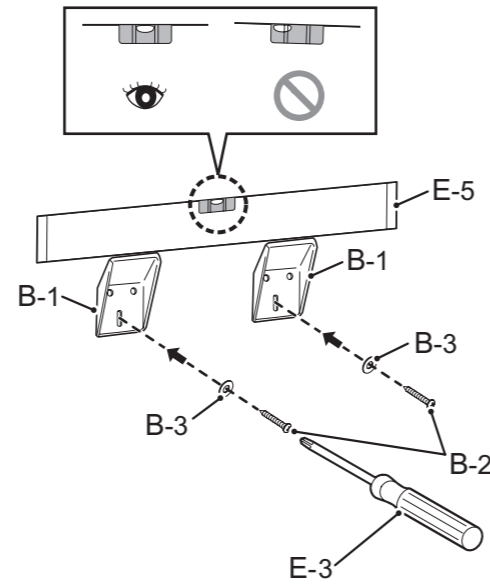

4

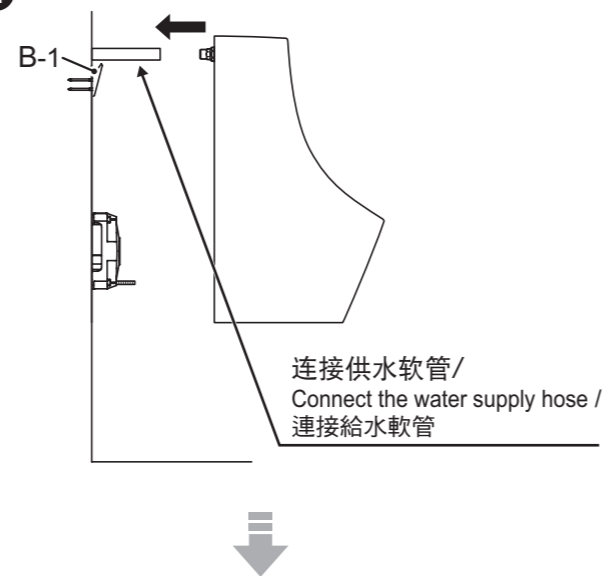

请在挂钩挂上小便器 (A-1), 并调整挂钩 (B-1) 至规定位置。此时, 请勿在小便器安装密封圈 (C-7)。

Hang the urinal (A-1) from the back hangers (B-1) and adjust it to the indicated position. Do not install the wax ring (C-7) onto the urinal at this time.

請將小便斗 (A-1) 掛上掛鉤 (B-1) 上並調整掛鉤, 使小便斗位於指定位置。此時, 請勿將油泥 (C-7) 安裝至小便斗。

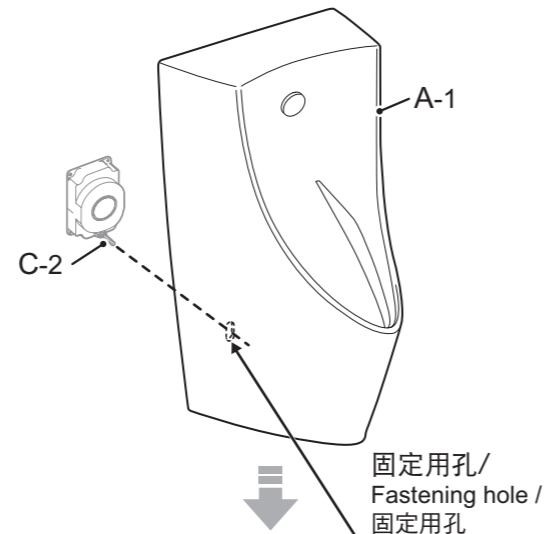

5

※安装小便器 (A-1) 时, 请注意不要损伤墙壁。 /
* When installing the urinal (A-1), be careful not to damage the wall. /
※安裝小便斗 (A-1) 時, 請小心不要損傷牆面。

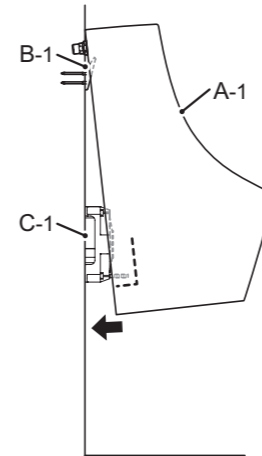

6

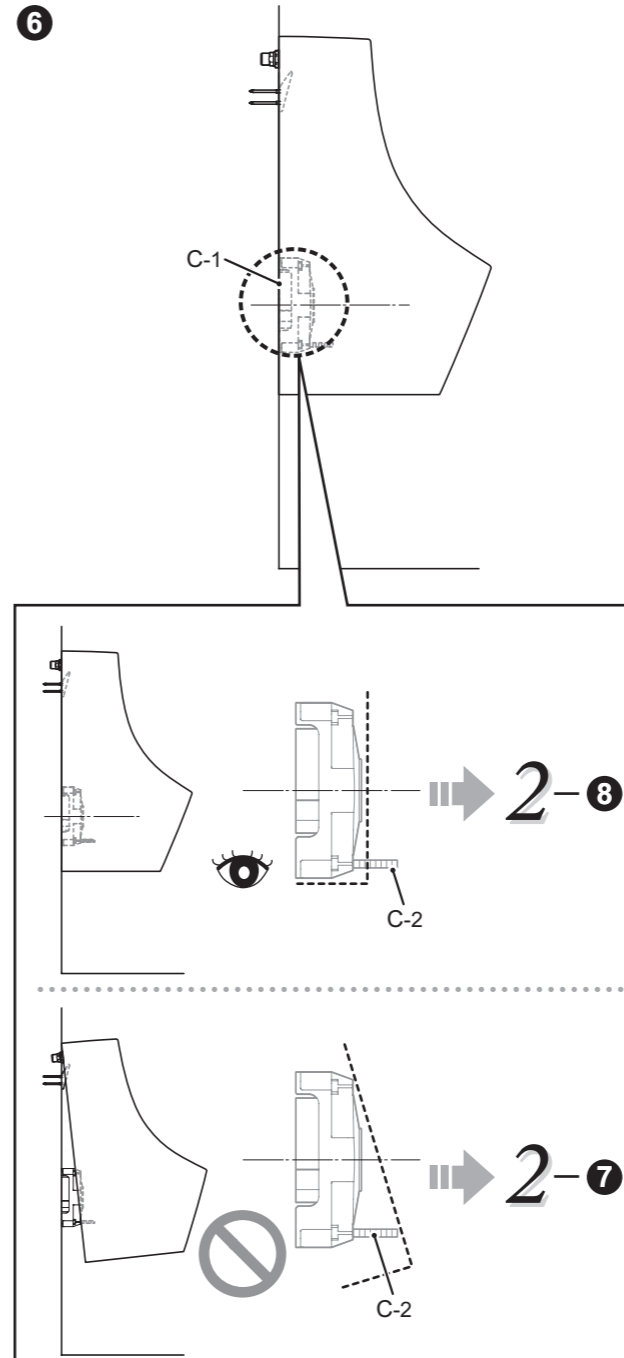

7

如小便器 (A-1) 安装不顺利时, 请从后背吊钩卸下小便器, 拆下供水软管后, 调整后背吊钩 (B-1)。

If the urinal (A-1) cannot be installed properly, remove the urinal from the hangers (B-1), then adjust the hangers after disconnecting the water supply hose. /
若無法順利安裝小便斗 (A-1), 請將小便斗從掛鉤 (B-1) 上取下, 並取下給水軟管後再調整掛鉤。

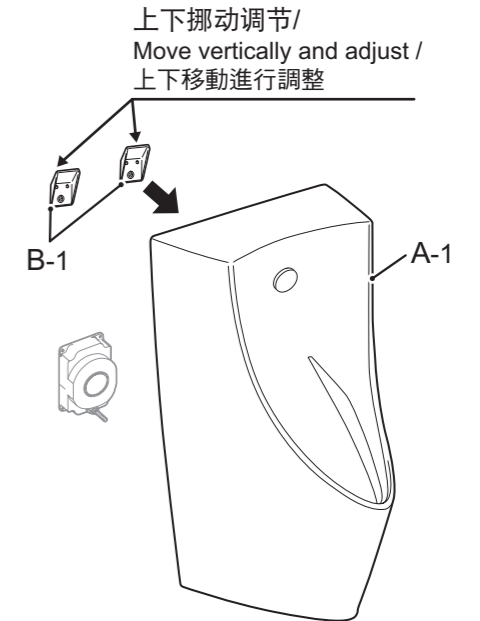

此时, 如果小便器 (A-1) 没有达到规定高度, 可拧松挂钩 (B-1) 的木螺钉 (B-2), 在与墙壁之间塞入金属片进行调整。

If the urinal (A-1) does not reach the indicated height, loosen the back hanger's (B-1) wood screws (B-2), then place a metal plate between it and the wall to adjust it.

小便斗 (A-1) 無法固定於規定高度時, 請鬆開掛鉤 (B-1) 的木螺絲 (B-2), 在與牆壁之間的縫隙夾入金屬片進行調整。

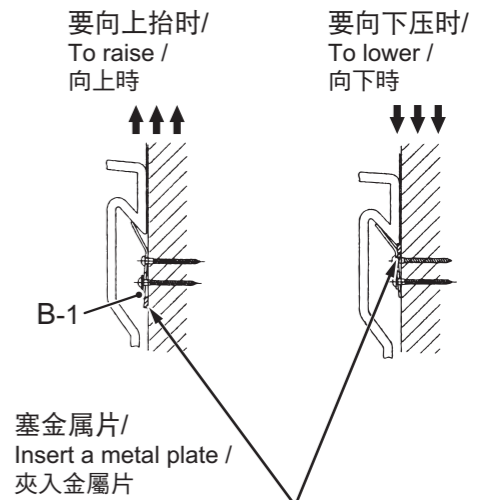

2-4

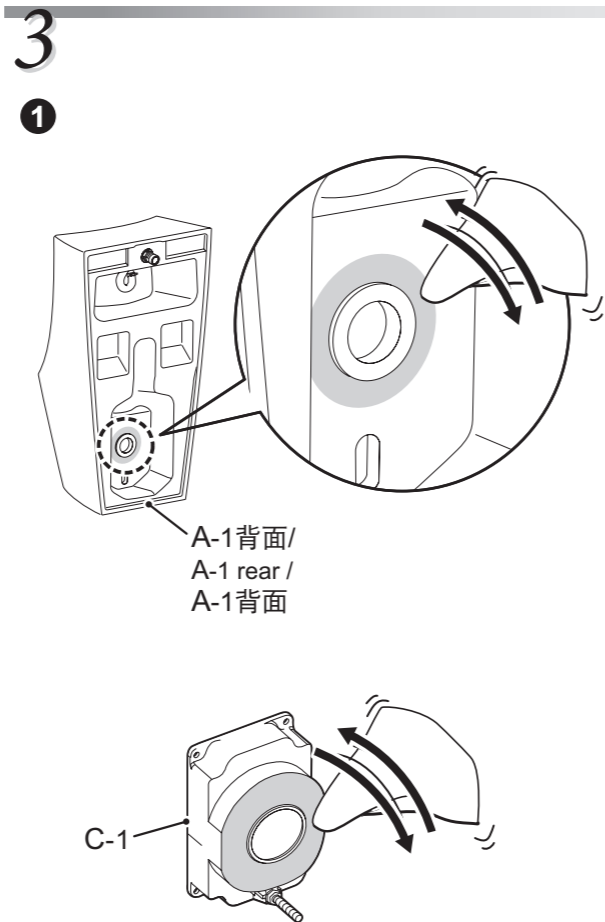
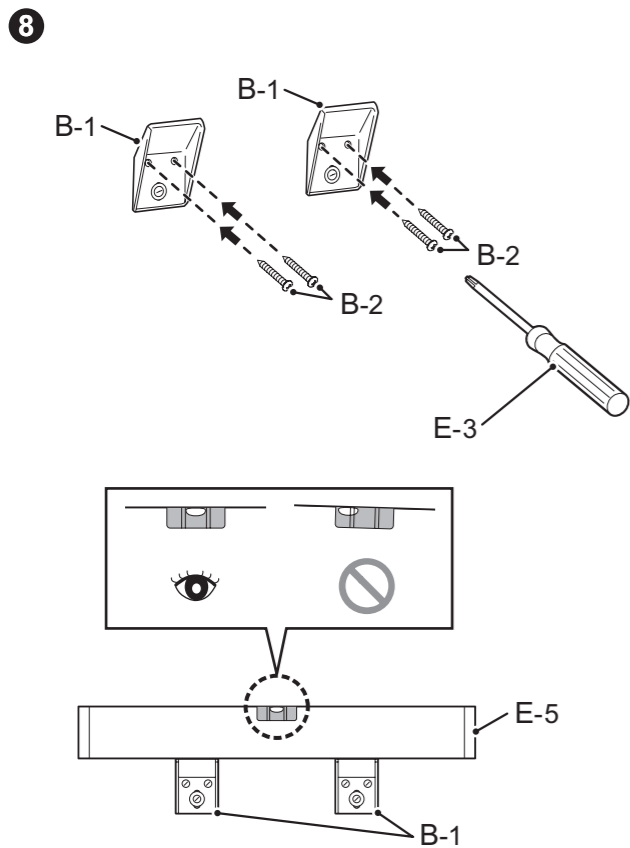

2 在小便器 (A-1) 安装密封圈 (C-7) 。 /
Install the wax ring (C-7) onto the urinal (A-1) 。 /
將油泥 (C-7) 安裝至小便斗 (A-1) 。

请使密封圈连接部朝上安装。 /
Face the wax ring joining section up. /
使用油泥時，請將油泥連接處朝上。

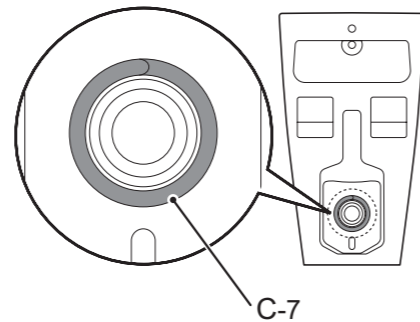

3 连接供水软管 /
Connect the water supply hose /
連接給水軟管

4 ※安装小便器 (A-1) 时，请注意不要损伤墙壁。 /
* When installing the urinal (A-1), be careful not to damage the wall. /
※安裝小便斗 (A-1) 時，請小心不要損傷牆面。

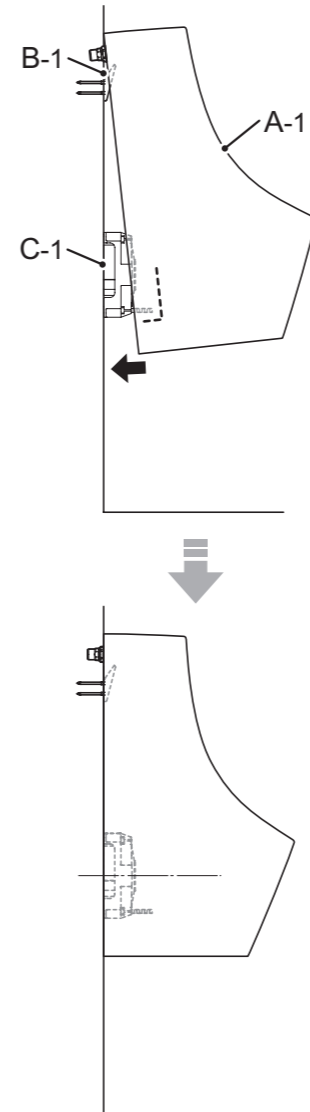

5 用垫圈 (大) (C-6) 与螺母 (C-3) 将法兰螺栓 (C-2) 固定在小便器 (A-1) 下方。
※垫圈 (大)、螺母和排水法兰包装在一起。
※注意不要将螺母拧得过紧，使小便器主体产生裂纹。
※注意不要让小便器主体碰到止水栓。 /

Fix the flange bolt (C-6) to the lower part of the urinal (A-1) with the washer (large) (C-2) and nut (C-3).
* The washer (large) and nut are packaged with the drainage flange.
* Be careful not to tighten the nut too strongly and crack the urinal unit.
* Be careful that the shutoff valve does not strike the urinal unit. /

使用垫圈 (大) (C-6)、螺帽 (C-3)，將法蘭螺栓 (C-2) 固定於小便斗 (A-1) 下方。
※墊圈 (大) 及螺帽，與排水法蘭同包裝。
※請注意，螺栓過度鎖緊時，小便斗本體可能破裂。
※請注意，小便斗本體請勿碰觸到止水栓。

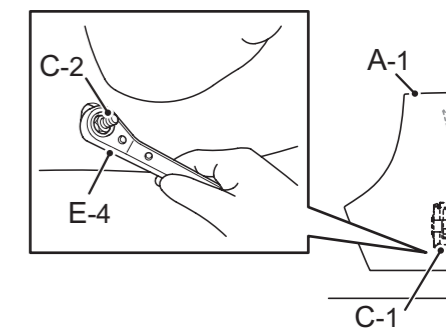

※螺母对边距离为13mm。
拧紧螺母时，推荐使用全长在150mm以下的棘轮箱扳手 (E-4) 。 /

* The hex size of the nut is 13 mm.
A board ratchet wrench (E-4) with a total length of 150 mm or less is recommended to tighten the nut. /

※螺帽的對邊為13mm。
鎖緊螺帽時，建議使用150mm以下的棘輪板手 (E-4) 。

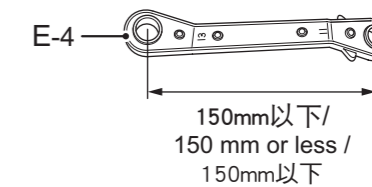

6 确认小便器 (A-1) 紧贴墙壁后，确认小便器无晃动。
※如小便器与墙壁间有缝隙或晃动时，先拧松螺母，使小便器紧贴墙壁后重新固定。 /

After confirming that the urinal (A-1) is tightly fitted against the wall, make sure that it does not rattle.

* If there is a gap between the urinal and the wall or if the urinal rattles, loosen the nut, and then refasten it after fitting the urinal tightly against the wall. /

確認小便斗 (A-1) 緊密貼合牆壁後，確認小便斗無鬆動。
※小便斗與牆壁之間有縫隙或鬆動時，請先將螺帽鬆開，使小便斗與牆壁緊密貼合後再重新固定。

ZH	⚠ 注意
禁止	● 安装小便器 (A-1) 时，不要从排水口侧安装 否则可能会从排水法兰 (C-1) 处漏水，造成财产损失，如淋湿家具等。
EN	⚠ CAUTION
Prohibited	● Do not install the urinal (A-1) from the drainage outlet side Doing so could cause water leaks from the drainage flange (C-1) that could result in flooding damage to property, such as household belongings.
TW	⚠ 注意
禁止	● 安裝小便斗 (A-1) 本體時，不可由排水口側安裝 若排水法蘭 (C-1) 漏水，可能會發生漏水弄溼設備等的財物損失。