

See "Troubleshooting" (P.14) before asking for repairs.

For advice on repairs and handling,
first contact your dealer.

Dealer:

Address:

Tel:

TOTO Asia Oceania Pte. Ltd.

Telephone: 65-6744-6955

FAX : 65-6841-0819

Address : 10 Eunos Road 8 #12-07 Singapore Post Centre Singapore 408600

Website : asia.toto.com

TOTO KOREA LTD.

전화번호 : (02)-3141-8236

FAX 번호 : (02)-3141-8240

주소 : 서울시 마포구 상수동 351-16번지 로이코빌딩 3층

홈페이지 : http://www.totokr.co.kr

TOTO LTD.

TOTO web site <http://www.toto.com/index.htm>

TOTO

铜合金壁式单柄双控暗装 洗面器水嘴

型号

TLP02309型
TLP02310型

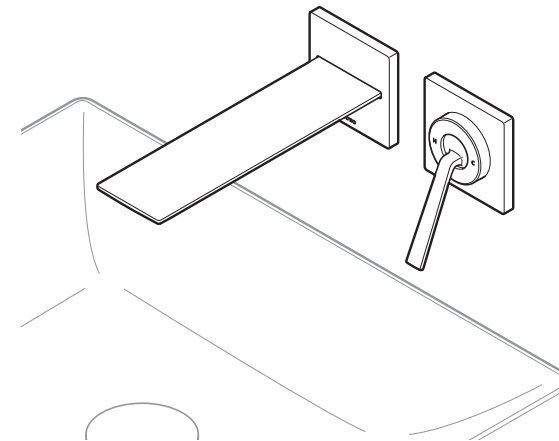

- ◆首先对您选购本公司的产品表示我们最真诚的谢意。请务必仔细阅读本使用说明书并正确地进行使用。
- ◆请妥善保管本使用说明书，以便在必要时可随时取阅。

使用说明书

使用前

安全上的注意事项 1-4

各部位名称 5

使用方法

使用方法 6-8

保养

日常保养 9-11

定期保养 12-13

这种情况时

是故障吗? 14-15



售后服务 16-17

咨询和报修 见封底





安全上的注意事项 (为了安全起见, 请务必遵守)



使用前, 请仔细阅读本「安全上的注意事项」的内容, 并正确地使用。



- 阅读后, 请务必妥善保管在使用者随时可取阅之处。
- 为了安全、正确地使用产品, 防止给您或者他人的人身及财产安全造成损失, 此说明书采用了许多标志。各标志与含义如下:

标志	含义
 警告	此标志表示无视此标志的内容, 进行误操作的话, 可能导致人员死亡或重伤。
 注意	此标志表示无视此标志的内容, 进行误操作的话, 可能造成人员伤害或物质财产损失。

■ 需遵守的内容通过以下标志加以区分、说明。

	 表示不可行, “禁止”之意。 左图表示“禁止拆解”。
	 表示必须“强制”实行的内容。 左图表示“必须实行”。

 警告	
 禁止	供热水温度不得超过90°C, 建议供热水温度为60°C。供热水管请勿使用蒸汽。 否则可能造成产品使用寿命缩短, 易破损、烫伤, 以及由于漏水造成家庭财产污损。
	请勿擅自进行诸如安装非本产品结构零件以外部件, 或拆除零件等改装。 否则, 可能因产品性能受损导致烫伤、受伤, 或因漏水而引起家具浸湿等财产损失。
 禁止拆解	非专业维修人员绝对不能进行说明书记载检修项目外的产品拆解、修理和改造。 否则, 可能因产品受损导致烫伤、受伤, 或因漏水而引起家具浸湿等财产损失。

 警告	
 禁止碰触	使用时请勿直接接触手柄装饰盖 供热水侧处于高温状态可能会造成烫伤。
	使用高温热水时, 切勿直接接触水嘴本体及手柄装饰盖。 处于高温状态的水嘴本体及手柄装饰盖可能会造成烫伤。
 必须实行	使用前, 请务必确认手柄的位置 使用热水时, 直接从热水侧放水, 会因流出的高温热水而烫伤。为避免烫伤, 请先从冷水侧打开, 然后慢慢地调整到适当的水温。
	使用高温热水后, 请短暂放冷水 否则在下次使用时, 可能会因产品内残留的高温热水而造成烫伤。
	请定期 (一年两次以上) 检查给排水管周围有无漏水或松动现象。 否则, 可能因老化或磨损等原因导致烫伤·受伤、因漏水导致浸湿财产、致使财物受损。
	冷水水压必须高于热水水压或同等于热水水压 否则会因无法正常地调节温度而导致烫伤。如必须给热水侧加压时, 热水侧压力也必须低于冷水水压。

⚠ 注意

不要施加强力或冲击。
否则可能会造成破损，以及因发生漏水而造成的家具浸湿等财产损失。

请勿对产品施以重压，或拽拉产品。
否则可能会造成破损，以及因发生漏水而造成的家具浸湿等财产损失。

请勿对拉杆施加过度的压力、撞击，或拉出拉杆。
否则可能导致产品无法良好运作或发生故障。



禁止

请勿使把手承受过大的力量。
否则可能会造成破损，以及因发生漏水而造成的家具浸湿等财产损失。

请勿忽视产品各部分的松动现象。
否则会因零部件损坏，或表面镀层出现裂纹而导致受伤。
如出现以上现象，请立即委托修理。

请勿对电镀层表面施加强力或冲击。
否则会因零部件损坏，或表面镀层出现裂纹而导致受伤。如出现以上现象，请立即委托修理。

⚠ 注意

请勿使用中性洗涤剂以外的洗涤剂
(请参见第11页之内容。)
否则可能会造成产品变色或损坏



禁止

请勿使化妆品等附着于水嘴表面。
如果将卸妆剂、发胶、洗发液、染发剂等附着于树脂零件上放置不管，
则可能会造成产品变色或损坏。如意外附着于产品时，请立即用水洗
干净。

请勿在室外或可能结冰的地方使用
否则可能导致部件破损，从而因漏水浸湿财物致使财物受损。因结
冰造成的破损，即使在质保期内也属于收费修理。
在可能结冰时，请保持水嘴周围温度，防止降至冰点以下

请慢慢地操作把
关闭过快时，水管会发出「咚」的撞击声音，使水管收到冲击进而可
能导致漏水而造成的家具浸湿等财产损失。



必须实行

长期不使用时，请务必关闭供水管道总阀。
以免发生漏水等意外事故。

残障人士及智力能力缺陷和常识缺乏的人（包括儿童）需要在
专人监护下使用本产品。

安装本产品，请委托法资质的专业人员安装。

各部位名称

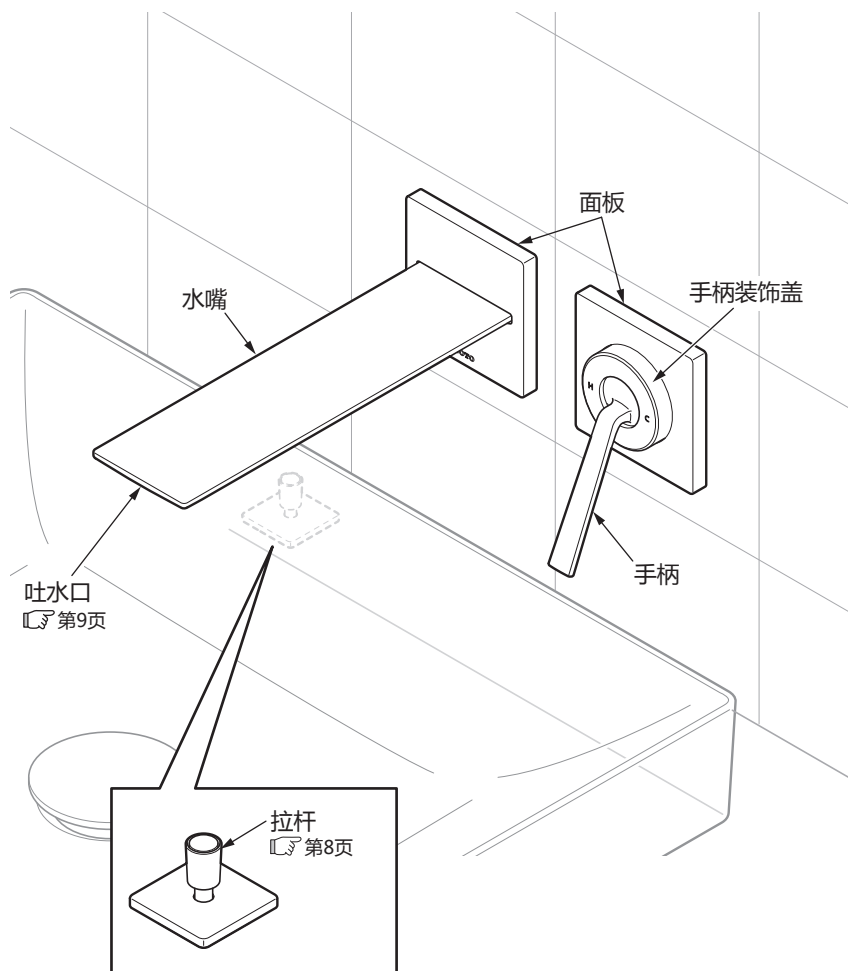

使用方法

温度调节方法

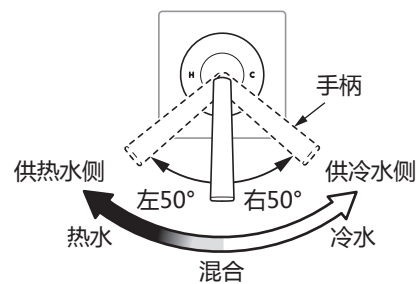

旋转手柄。

以中央部为基点，旋到右侧会出来冷水，愈往左侧旋转，水温愈高。

向左侧旋到底为最高温度位置。

吐水（冷·热水）

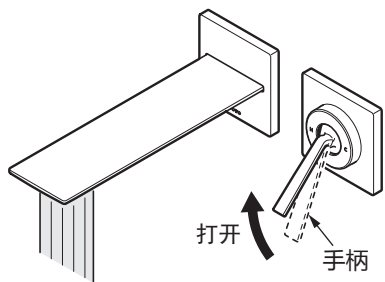

打开手柄。

开始吐水。
完全打开则流量最大。

停止吐水（冷·热水）

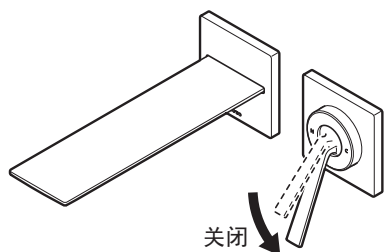

关闭手柄

停止吐水。

请慢慢地操作把手。否则可能会出现水锤现象。

注意

- 「水锤现象」是指关闭过快发出「咚」的噪声，并非产品问题。因可能导致供水管损伤或漏水，所以必须慢慢地关闭手柄，以免出现水锤现象。

止水塞的开关（仅限安装排水配件时）

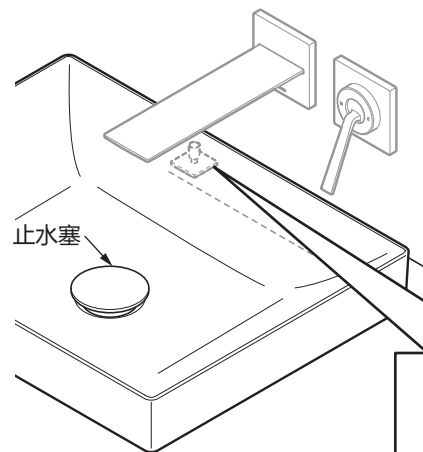

拉出拉杆。

关闭止水塞，可在洗面器中储水。
按下拉杆，就打开止水塞，开始排水。

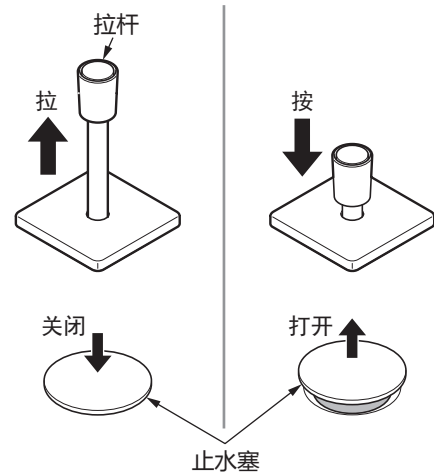

日常保养

为了有效地发挥产品功能以及让您舒适、卫生地使用，请作好日常保养。

吐水口的保养

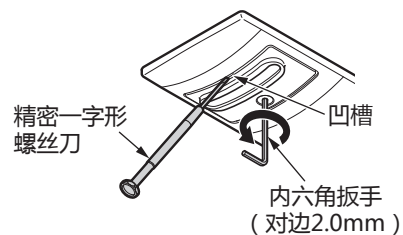

1. 用内六角扳手(对边2.0mm)松开沉头螺丝而拆下。

为避免零件丢失，请关闭止水塞(或用毛巾堵住止水塞)。

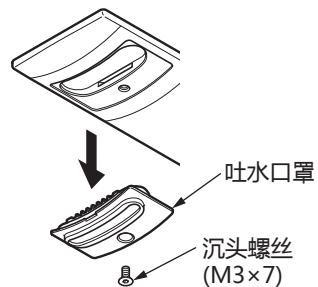

2. 将精密一字形螺丝刀插入吐水口罩与水嘴之间的凹槽，拆下吐水口罩。

3. 用牙刷等去除堵住吐水口罩内整流网的垃圾或污垢。



4. 将吐水口罩安装在水嘴上后用沉头螺丝固定。

用手指将吐水口罩按入水嘴后，拧紧固定螺丝。

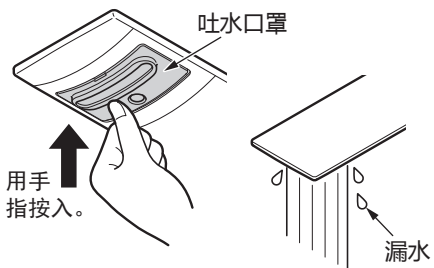

5. 安装结束后，检查吐水口部有无漏水。

吐水口罩未能正确安装时，请重新安装吐水口罩。

用软布擦拭保养

● 轻微污垢时

用冷水或温水将软布打湿后拧干，擦除污垢。

● 污垢严重时

用适量稀释好的餐具用中性洗涤剂沾湿软布，再用软布擦除污垢，然后用清水擦干净。

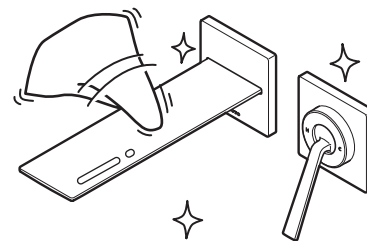

建议

切勿对水嘴施加过大的压力。

否则可能因水嘴弯曲、破损而造成漏水等意外事故。

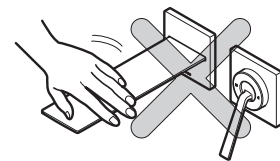

定期检查

为了能够安全、舒适地使用本产品，请务必进行下列检查。

产品的松动（一年两次以上）

与开始使用时相比，检查产品有无松动等异常部位。

如果在水管周围松动状态下继续使用时，会使供水管承受负载，并有导致漏水的可能。

另外，对松动等异常现象放任不管，会造成零部件损坏，或表面镀层出现裂纹而导致受伤。

发现有松动时，先拆下装饰盖，然后再重新拧紧固体本体的螺丝。

若仍未解决松动时，请委托经销商或代理店进行修理。（收费）

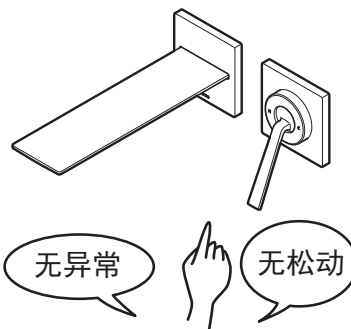

建议

请勿使用可能损坏产品表面的下列物品。

- 酸性清洗剂、含氯的漂白剂、碱性清洗剂
否则可能会造成产品表面变色或树脂零件损坏。
- 香蕉水、挥发油等溶剂
否则可能会造成橡胶或树脂零件损坏。
- 去污粉、研磨粉等含有粗颗粒物质的清洗剂
- 百洁布，刷子等
否则可能会损伤产品表面。

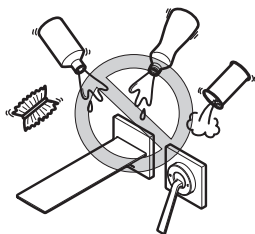

手柄的固定方法

※固定前，请关闭管道总阀。

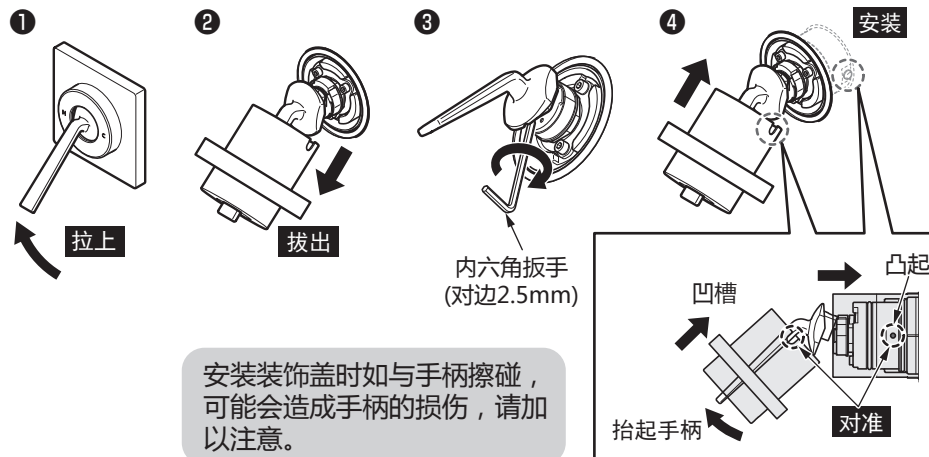

是故障码?

水嘴的固定方法

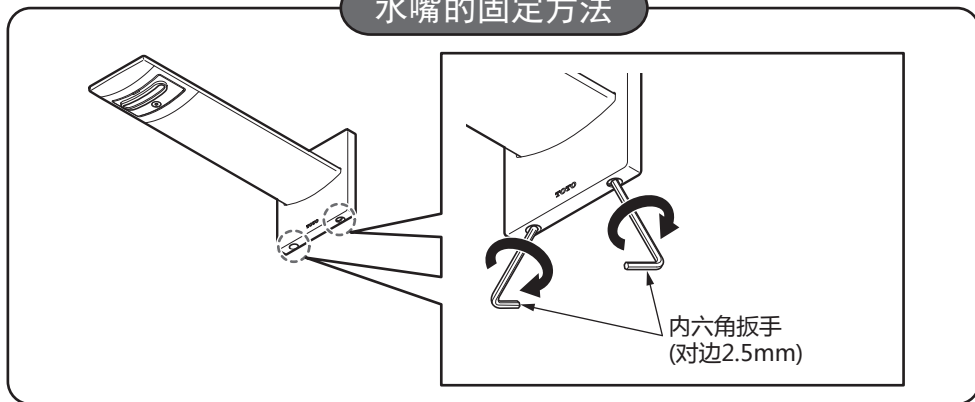

给排水管周围的漏水 (一年2次以上)

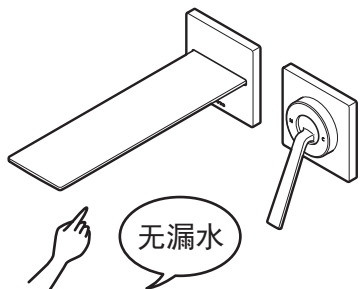

检查给排水管周围有无漏水

因老化和磨损坏, 进而导致受伤、或因漏水导致浸湿财产等事故的发生。

发现漏水时, 请关闭管道总阀 (见14页), 然后请委托经销商或代理店进行修理。

紧急时的止水方法

发生给水管周围漏水、无法止水等紧急情况时, 请根据下图要领关闭进水角阀或管道总阀。

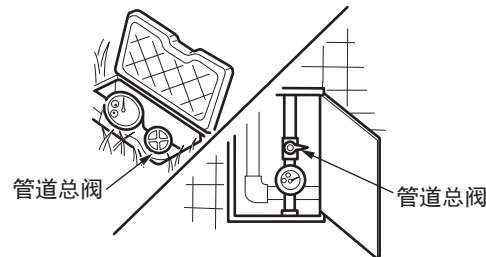

- 下列情况并非故障。委托修理前, 请先检查以下项目, 如果仍未解决时, 请委托经销商或代理店进行修理。详情请确认售后服务部分(第16页)。

委托修理前			
现象	检查项目	处置方法	参照页数
不止水	手柄是否降低到止水位置? (是否完全关闭)	将手柄降低到止水位置。	第7页
流量小	吐水口是否堵塞?	清洁吐水口。	第9页
	与流量可调式燃气热水器搭配使用时, 燃气热水器的设置是否合适?	请将燃气热水器的流量调整至合适的范围。	—
只有冷水	热水供给设备是否供给充足的热水?	确认热水供给设备的设定温度和工作状态。	—
无法调节温度	热水供给设备是否供给充足的热水?	确认热水供给设备的设定温度和工作状态。	—
	吐水口是否堵塞?	清洁吐水口。	第9页
手柄松动	手柄的固定螺栓是否松开?	重新拧紧松开的螺栓。	第12页
只出冷水	以中央部为基点, 手柄是否旋至左侧?	将手柄旋至左侧。	第6页

售后服务

●下列现象并非故障。

现象	说明	参照页数
与初次使用时相比，使用一段时间后，可能会感到把手操作时有些紧	这是因内部零件相互磨合、适应后的结果，并非故障。	—

小知识

零件（陶瓷阀芯）的相互磨合

将手柄往上下或左右操作时，图中的A和B零件相互摩擦。

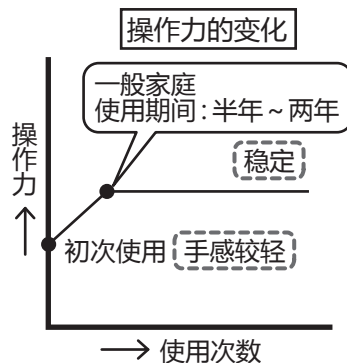
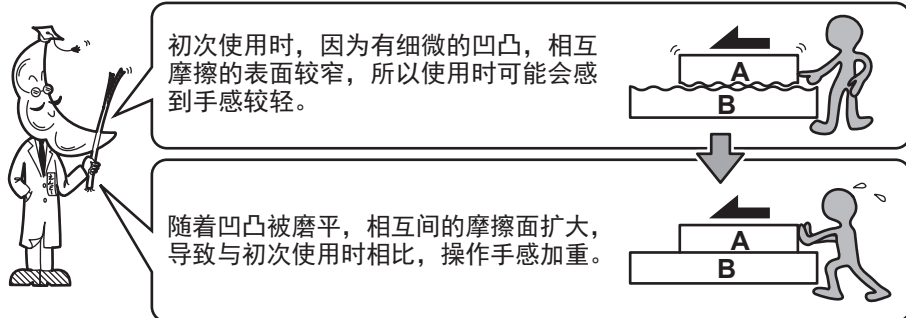

使用年数



[委托修理前，请确认「是故障吗？」之内容（第16页）。]

零件的更换

免费修理时换下的零件、产品属于东陶（中国）有限公司所有。

磨损·老化零件的更换

- 阀芯或密封圈磨损和老化，可能会造成漏水。此时，需要更换该零件。
- 请委托经销商或代理店更换磨损·老化零件。

委托修理时

[委托修理地点]
经销商或代理店

- [需联络的内容]
- ① 地址、姓名、电话号码
 - ② 产品名称 ③ 型号
 - ④ 安装日期
 - ⑤ 故障内容、异常情况
(从哪里漏水等)
 - ⑥ 希望到府上的维修日期

请通过贴在○部分的标签，来确认产品型号。

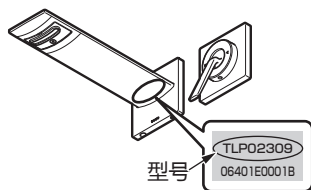

委托修理前，请确认「是故障吗?」之项（第14页）。

需要询问修理和使用时，
请首先与购买的安装公司或经销商联系

安装公司·经销商

邮编

电话号码

—

经销商：东陶（中国）有限公司

全国售后服务电话：800-820-9787 (固定电话)

400-820-9787 (手机用户)

地址：北京市朝阳区光华路1号 北京嘉里中心北楼1915室

网址：www.toto.com.cn

TOTO株式会社

TOTO网页 <http://www.toto.com/index.htm>

2017.8
03N52E

TOTO

Wall-Mounted Single Handle Faucet (Embedded Type)

Model
Number

TLP02309
TLP02310

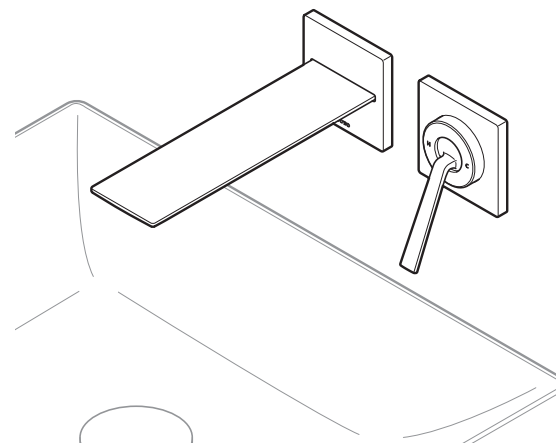

- ◆ Thank you for choosing the Wall-Mounted Single Handle Faucet (Embedded Type). For the best performance, please read this manual carefully.
- ◆ Keep this manual in a safe handy place for future reference.

Operation Manual

Introduction

Safety Precautions 1-4

Names of Parts 5

How to Use

How to use 6-8

Maintenance

Daily Care 9-11

Periodic Checks 12-13

What to Do?

Troubleshooting 14-15

After-Sale Services 16-17



Information Back cover

Safety Precautions





(Be sure to follow all precautions for safety sake.)



Read the section on “Safety Precautions” thoroughly to ensure proper use.



- Read this manual carefully and keep it where it is easily available.
- This manual employs various indications in order to install the product safely and properly and to prevent harm to the customer and other people as well as, damage to their property. The indications and meanings are as follows.

Symbol	Meaning
 WARNING	This indication means that if the content in the column of this indication is ignored or handled wrongly, death or serious injury may occur.
 CAUTION	This indication means that if the content in the column of this indication is ignored or handled wrongly, injury or property damage may occur.

■ The contents you must observe are classified into the following symbols; their meanings are explained.

	 Indicates things that you must not do as “Prohibited”. The left figure indicates that “Disassembly is Prohibited”.
	 Indicates things that you must do without fail as “Mandatory”. The left figure indicates to “Execute it without fail”.

 WARNING	
 Prohibited	Do not use the water hotter than 90°C. If the water hotter than 90°C is used, the water may scald you and the life of the faucet may shorten causing it to break and leak water that may wet household articles and cause damage to your property.
	Do not modify the product using parts other than those that constitute this product or by mounting other parts or dismounting original parts. Otherwise, the product may not perform to expectations and leak water that may wet household articles and cause damage to your property.
 Disassembly Prohibited	Do not disassemble parts other than those described in this manual. Otherwise, the water may scald or injure you and the product may break and leak water that may wet household articles and cause damage to your property.

 WARNING	
 Do Not Touch	Do not directly touch the left side of the handle cover. The hot water supply side is hot and may scald you.
	When you use high-temperature hot water, do not directly touch the spout or handle cover. The spout, the water discharge port and the main body are hot and may scald you.
 Mandatory	Check the lever handle location before discharging water. If you discharge water from the hot water side, hot water comes out and may scald you. When you use hot water, start first with cold water and then adjust the water temperature slowly to desired temperature.
	After using hot water, flow cold water for a while. When you use the faucet the next time, the hot water that remains in the faucet comes out and may scald you.
	Periodically (More than twice a year) check around the piping for any water leaks and looseness. Part(s) may break due to deterioration and wear and you may be scalded or injured, and water may leak, wet household articles and cause damage to your property.
	Set the cold water supply pressure higher than the hot water supply pressure or set them to the same pressure. If the hot water supply pressure is set higher than the cold water supply pressure, the temperature cannot be adjusted to appropriate temperature and you may be scalded. When increasing the hot water supply pressure, be sure to set the hot water supply pressure lower than the cold water supply pressure or set them to the same pressure.

 **CAUTION**

Do not subject the product to strong force or impact.

Otherwise, the product may break and leak water that may wet household articles and cause damage to your property.

Do not put your body weight on the product or hang on the product.

The product may break and leak water that may wet household articles and cause damage to your property.

Do not subject the pulling bar to strong force or impact and do not pull it.

Otherwise, malfunction or trouble may be caused.

Do not subject the lever handle to strong force or impact.

The lever handle may break and leak water that may wet household articles and cause damage to your property.

Do not leave the abnormality-like looseness as it is.

If the abnormality-like looseness is left as it is, the part(s) may break and plated surfaces may crack whereby injuring you. If you detect any broken part(s) or cracked plated surfaces, immediately ask for repairs.

Do not strike or operate plated part(s) with undue force.

The plated surface may crack whereby injuring you. If the plated surface cracks, immediately ask for repairs.



Prohibited

 **CAUTION**

Do not use cleaning agents other than neutral detergent.

(Refer to page 11.)

If you use cleaning agents other than neutral detergent, the faucet may discolor or break.

Do not let cosmetics, etc. adhere to the faucet.

If cleansing agents, hairdressing, shampoos, hair dyes, etc. are left adhering to plastic parts, the product may discolor or break. If adhered, immediately wash away with water.

Do not use the product in any place where freezing can be expected.

Otherwise, the parts may break and leak water that may wet household articles and cause damage to your property. Repairs to parts broken due to freezing are subject to billing even within the warranty period. If freezing is anticipated, do not lower the temperature around the faucet below zero.

Operate the lever handle slowly.

If you close the water discharge port, a loud “banging” noise is heard as the piping is impacted by water hammering. In some cases, water may leak whereby wetting household articles and causing damage to your property.

If the product will not be used for a long period of time, close the main valve of the piping.

Unexpected accidents like water leaks may be caused.



Prohibited



Mandatory

Names of Parts

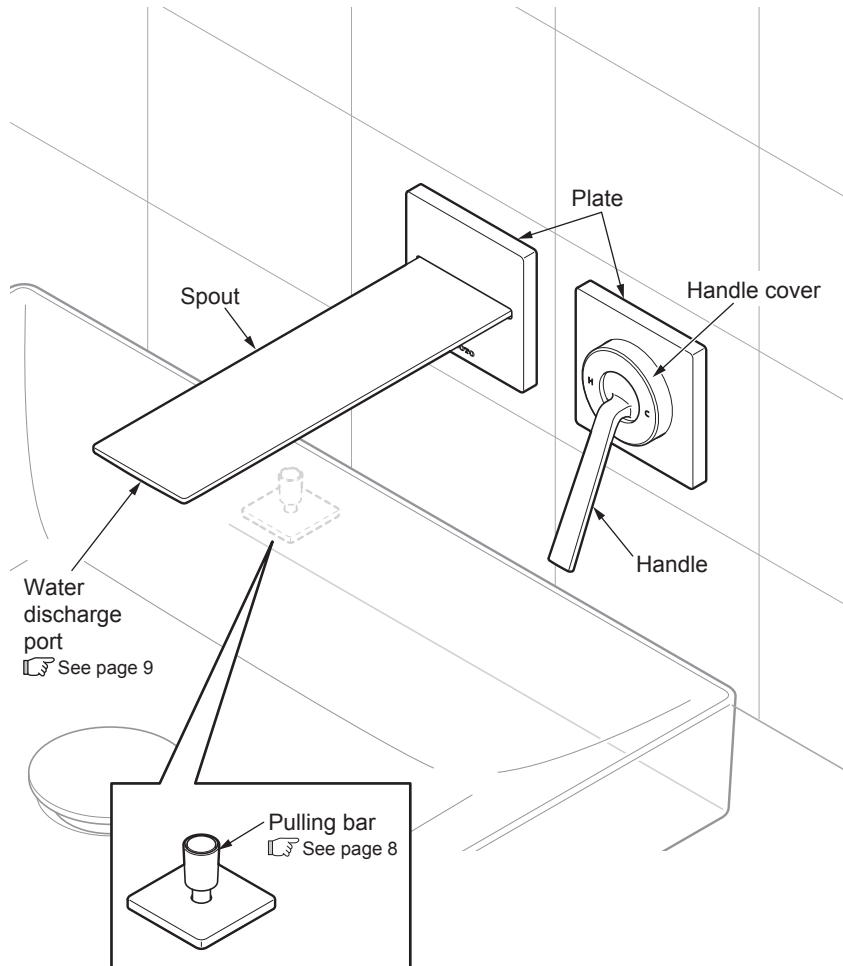

How to Use

How to adjust the temperature

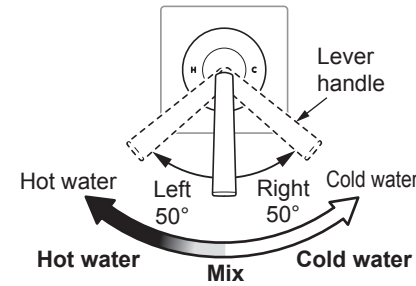

Turn the lever handle.
Cold water comes out if you turn the lever handle to the right of center. If you turn it to the left, the water temperature rises gradually.

If you turn the lever handle fully to the left, the water temperature rises to the maximum.

To use cold/hot water

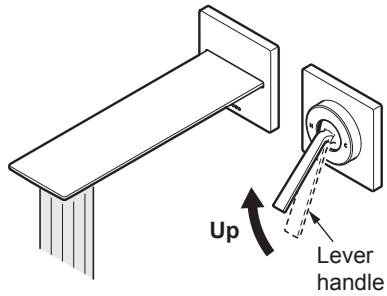

Lift the lever handle.

Water comes out.
At the highest position, the flowrate becomes the maximum.

To stop cold/hot water

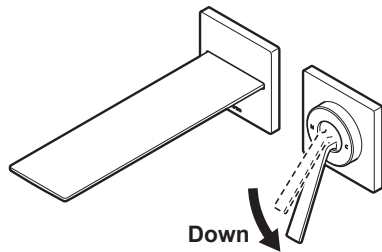

Lower the lever handle.

Water stops coming out.

Operate the lever handle slowly. In some cases, you may incur water hammering.

Note

- **“Water hammering”** is a phenomenon that causes a loud “banging” sound. It is not due to trouble with the faucet, but when the water is stopped suddenly. However, this phenomenon may cause damage to piping and leak water. Therefore, lower the lever handle slowly to avoid water hammering.

Open and close the Pop-up waste (only when the Pop-up waste are mounted).

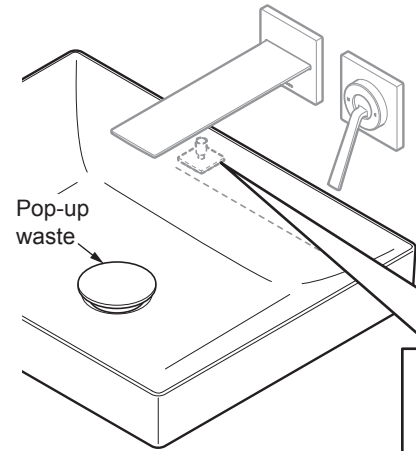

Pull the pulling bar.

The Pop-up waste close and water can be accumulated in a wash bowl.
If you push it, the Pop-up waste opens and water is drained.

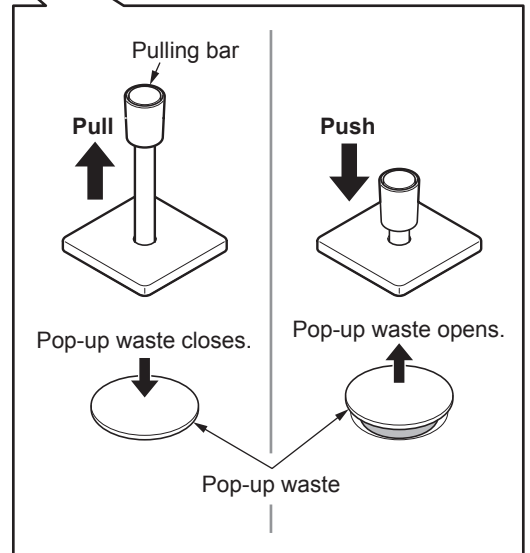

Daily Care

In order for the product to exert its full performance and to be used in a sanitary condition, perform care daily.

Care for the water discharge port

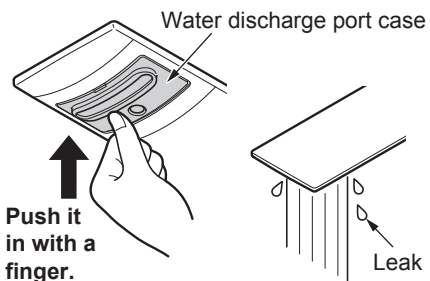
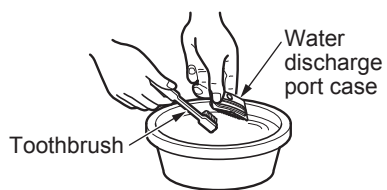
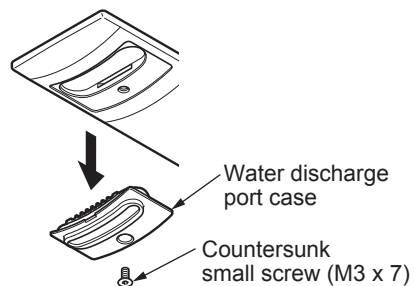
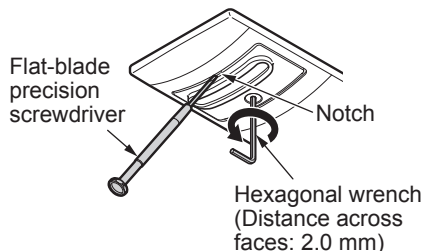

1. Loosen and remove the countersunk small screw using a hexagonal wrench (distance across faces: 2 mm).

Close the Pop-up waste without losing parts.
Block the Pop-up waste with a towel, etc

2. Insert the flat-blade precision screwdriver in the notch between the water discharge port case and the spout, and remove the water discharge port case.

3. Remove dirt and debris caught by the wire screen using a toothbrush, etc.

4. Assemble the water discharge port case on the spout and lock it place with the countersunk small screw.

Press the water discharge port case into the spout with a finger and tighten the setscrew.

5. When mounting work is complete, check the water discharge port for any water leaks.
If water discharge port case is not mounted properly, re-mount it.

Wiping with a cloth

● Slightly dirty

Soak a piece of cloth in cold or lukewarm water, wring well and wipe away dirt completely.

● Stubborn dirty

Wipe off dirt with a piece of cloth impregnated with appropriately diluted neutral bath cleaner, then blot up any residual dirt and water with a dry piece of cloth.

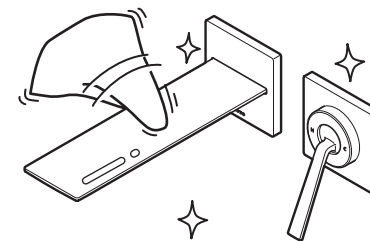

Notes

Do not apply excessive loads to the faucet.

Otherwise, the faucet may bend or break, whereby causing damage like water leaks, etc.

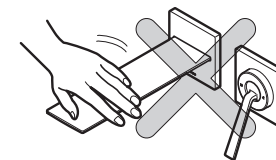

Periodic Checks

For safe and comfortable use, please conduct the following checks.

Looseness of the product (More than twice a year)

Check for any parts that seem abnormal such as being loose as compared to when you first began using the product.

If you continue to use the product with loose piping, load is applied to the pipe(s) and may result in water leakage.

If you leave any abnormality like looseness unfixed, part(s) may break or plated surfaces may crack whereby injuring you.

If you find a loose part, remove the cap and retighten the screw that anchors the main body. If the looseness cannot be fixed, ask your dealer or seller for repairs (subject to billing).

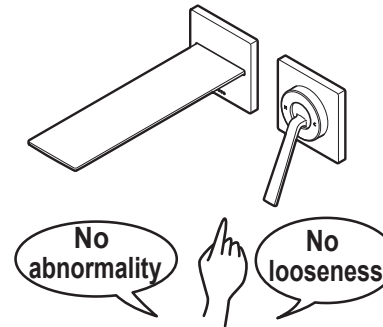

Notes

Do not use the materials that may break the faucet.

- **Acidic detergents, chlorine bleaches and alkali detergents**
The faucet surface may discolor or the plastic part(s) may break.
- **Solvents such as thinner, benzene, etc.**
Rubber and plastic part(s) may break.
- **Detergents that contain coarse particles such as cleansers, polishing powders, etc.**
- **Nylon scrubbers, scrubbers, brushes, etc.**
The faucet surface may be damaged.

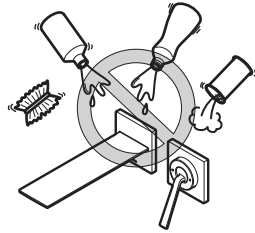

How to anchor the lever handle

*Close the main valve of piping before anchoring.

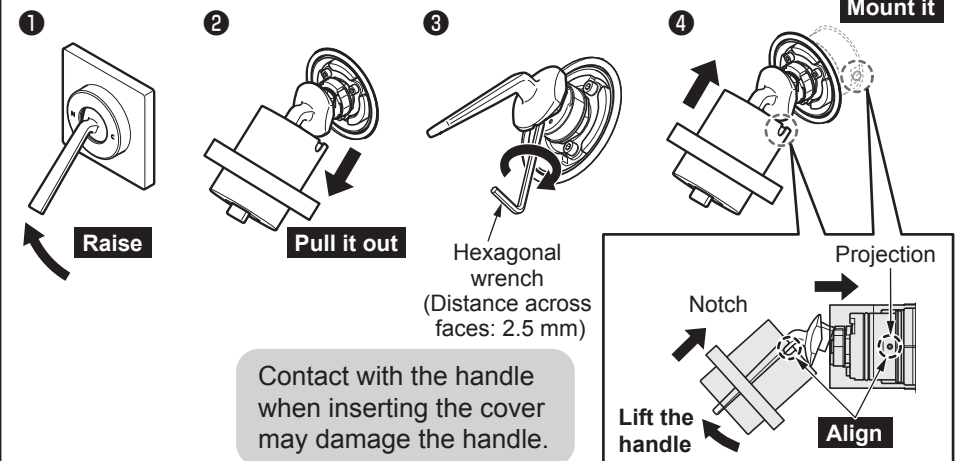

Troubleshooting

How to anchor the spout

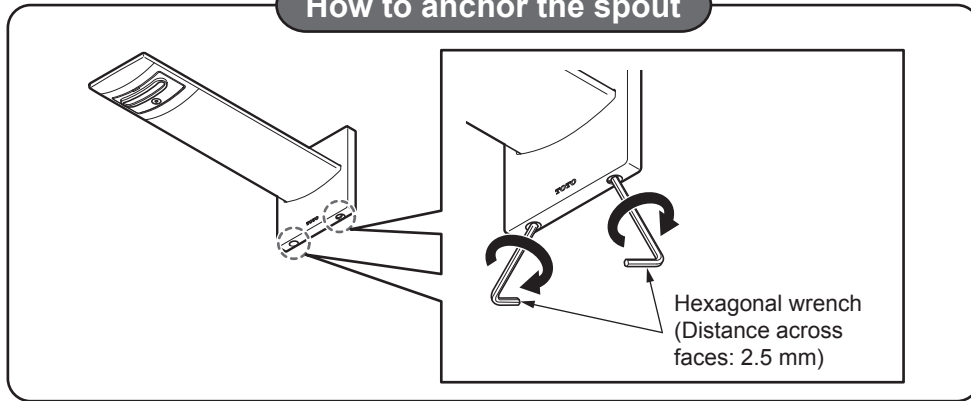

Water leak around piping (More than twice a year)

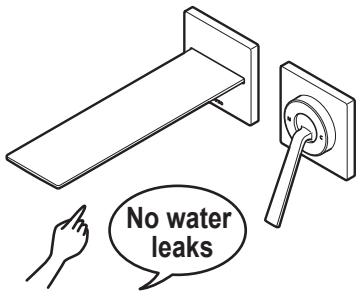

Check around piping for any water leaks.

Part(s) may break due to deterioration or wear, and you may be injured, and water may leak, wet household articles and cause damage to your property.

If water leaks, close the water shutoff valve and the main valve (see Page 14) and ask your dealer or seller for repair.

How to stop water in an emergency

In case of an emergency such as leaking water around the piping or water does not stop flowing, close the water shutoff valve or the main valve as shown in figure below.

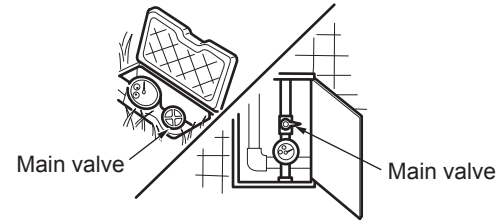

- **The following phenomena are not troubles.** Before asking for repairs, check the following points. If the troubles persist, ask your dealer for repairs. For details, check the after-sale services (page 16).

Before asking for repairs

Phenomena	Check Point	Remedy	Ref. Page
Water does not stop.	Is the lever handle lowered down to the water stop position? (Is the water stop valve fully close?)	Lower the lever handle down to the water stop position.	Page 7
The flowrate is too slow.	Is the water discharge port clogged?	Clean the water discharge port.	Page 9
	If the single handle faucet is used in combination with a gas water heater, is the capacity set appropriately for the capacity change type?	Set the appropriate capacity.	—
Only cold water comes out.	Is a sufficient volume of hot water coming from the water heater?	Check the water heating temperature and the operation of the water heater.	—
Temperature cannot be adjusted well.	Is a sufficient volume of hot water coming from the water heater?	Check the water heating temperature and the operation of the water heater.	—
	Is the water discharge port clogged?	Clean the water discharge port.	Page 9
Lever handle is loose.	Is the screw that anchors the lever handle loose?	Retighten the loose screw.	Page 12
Only cold water comes out.	Is the lever handle turned to the left side of center?	Turn the lever handle to the left side.	Page 6

- The following phenomena may occur but they are **not due to any trouble**.

Phenomena	Explanation	Ref. Page
Handle operation is heavier that when first using the product.	This is due to the fact that the parts inside the product fit each other well and become stable during use. This is not due to any trouble.	—

Tip

Fitness of parts (Ceramic valves)

When you move the handle up and down or to the right and left, parts A and B shown in the figure rub against each other.



When first using the product, since the indents are minute and the friction area is very small, both parts readily move.

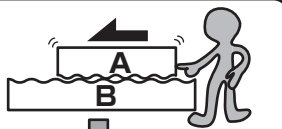

The indents are worn and the friction area becomes large. Therefore, a force somewhat stronger than when first using the product is needed.

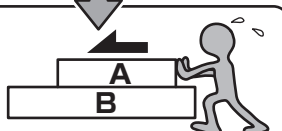

Change of operation force

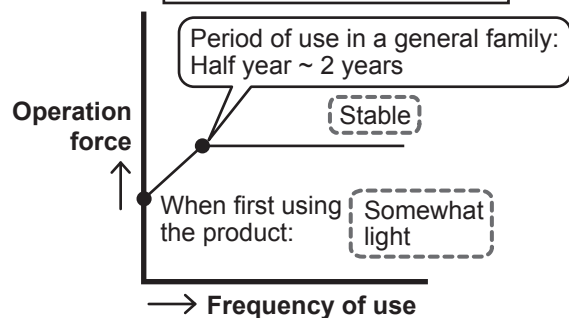

After-Sale Services

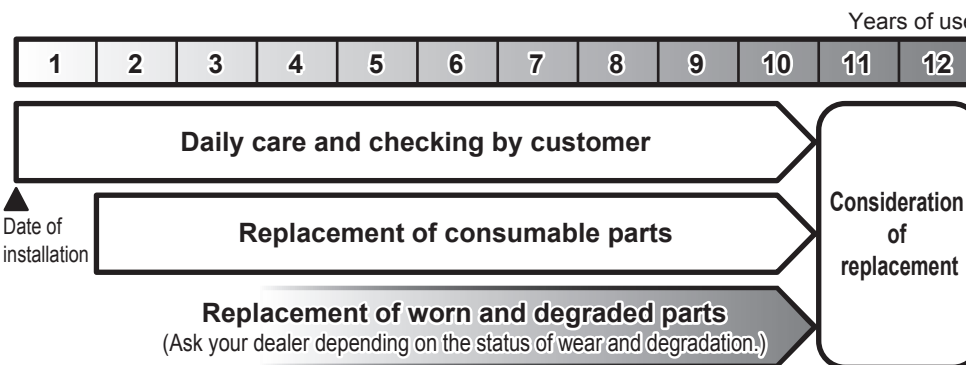

[Before asking for repairs, please check “Troubleshooting” (Page 14).]

Replacement of part(s)

Parts and products that are dismantled for repairs belong to TOTO.

Replacement of parts subject to wear and deterioration

- If the valve and packing wear or deteriorate, water may leak.
Replacement of applicable parts is necessary.
- Ask **the place of purchase** to replace worn or deteriorated parts.

When asking for repairs

[Where to ask for repair]

Your dealer or seller

[Information we want to know]

- (1) Address, name and telephone number
- (2) Name of product (3) Model number
- (4) Date of installation
- (5) Details of trouble and status of abnormality
(From where water leaks, etc.)
- (6) Desired date of visit

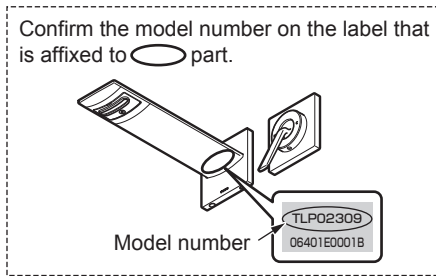

MEMO